

MPS 02.1

Metal Particle Sensor



Instruction manual

Version 1.1

Serial-no.:

Version valid from: 31.05.2012

Index

	Page
1. SAFETY INFORMATION	3
1.1. Dangers of maloperation	3
1.2. Intended applications	3
2. OPERATION AND INSTALLATION	10
2.1. General informations	10
2.2. Measuring principle of the MPS 02.1	10
2.3. Output signal of the sensor	10
2.4. Sensor installation	11
2.5. Electrical connection of the MPS 02.1	12
3. APPENDIX	13
3.1. Technical Data	13
3.2. Pin assignment	13
3.3. Application areas - Compatibility	14
3.4. Trouble shooting	14
3.5. Shipment/ spare parts	14

1. Safety information

1.1. Dangers of maloperation

The **MPS 02.1** underwent a safety check according to IEC 1010-1/ EN 61010 – 1, part 1. Integrated safety elements ensure safe operation if the device is used as it was intended.

In case of maloperation or abuse, as well as in case of insensitivity for application limits and safety regulations, the following threats can occur for:

- Life or physical condition of the operator,
- the **MPS 02.1**, as well as connected machines and systems connected,
- the accuracy of measurements of the **MPS 02.1**,
- the environment.

This manual contains information and safety advice, which ensure risk free operations and which help to keep the device in an ideal condition.

Therefore it is necessary that all people involved in operating and maintaining the device do note this manual unconditionally.

1.2. Intended applications

The **MPS 02.1** is an efficient and robust inline diagnostic measuring system for detecting metal particles > 260 µm in oil.

It works very reliably and does fulfil all requirements of daily measurements.

The set is intended and tested to operate with all usual hydraulic and gear fluids as well as synthetic esters.

Application limits:

Maximum acceptable pressure on the sensor element
Maximum oil temperature

20 bar / 290 psi
85° C / 185 °F

Generally, the **MPS 02.1** has to be operated with 24 V DC (ripple < 300 mV_{pp}).

2. Operation and Installation

2.1. General informations

The metal particle sensor MPS 02.1 serves the purpose of detecting metal particles in moving hydraulic and lubricating fluids (also see fluid compatibility in chapter 3.3). Therefore, the sensor has to be installed permanently into the hydraulic or the lubricating cycle, so that the fluid, which is being monitored, is permanently flowing through the measuring channel of the sensor.

A standard signal indicates that a metal particle was detected and has passed through the channel. The exact size or the type of metal detected can not be distinguished explicitly by this signal.

The minimum particle size which can be detected is defined as iron balls with a diameter of 260 μm at a volume flow within the channel of 30 l/min.

Interpretation of measurements is up to the operator, e.g. number of particles per time unit.

Typical applications of the sensor are:

- Inexpensive, continuous monitoring of large-scale gears for incipient heavy wear with the increasing number of particles per time unit.
- Monitoring component cleanliness, e.g. on flushing test stands.

2.2. Measuring principle of the MPS 02.1

The measurement is based on a multiple inductor technique.

If passing through the system of inductors, metal particles will be detected with the help of a high frequency magnetic field.

2.3. Output signal of the sensor

The signal induced by the metal particle passing the coil assembly processed inside the sensor. If a metal particle is detected a standard pulse signal is sent to the output.

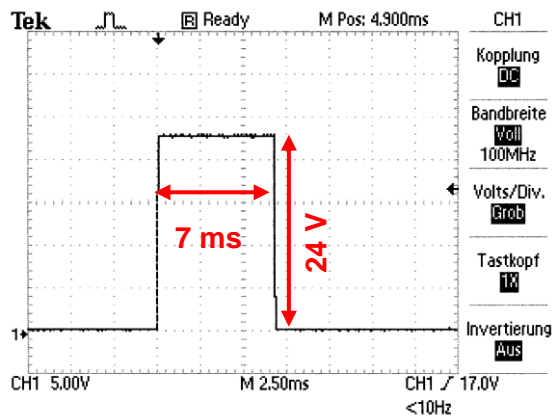

The standard signal is a square pulse with amplitude of 24 V and a pulse length of 7 ms at a sensor operating voltage of 24 V DC.

A second, dual output signal serves the purpose of self-diagnostics of the sensor's electronic circuit.

A „high“-level of 24V DC indicates proper condition. Corresponding to this, a „low“-level indicates faulty condition. The diagnostic signal doesn't give information if the oil is actually flowing through the sensor. The operator has to take care of this.

2.4. Sensor installation

The **MPS 02.1** is installed at an appropriate point of the system. All specified pressure and volume flow requirements have to be met. (see technical data, chapter 3.1).

- Insert the sensor in the system by using the 4 provided cylinder screws (ISO 4762 M10x140) and two SAE-flange 1" (not included in the shipment).

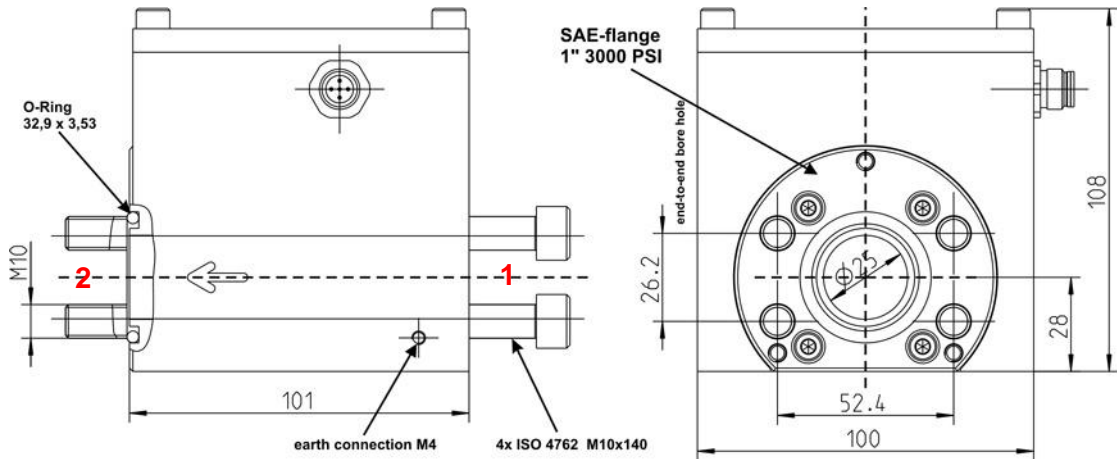

Attention: Look to it, that the SAE-flange 1" is using with the compatible counter flange!

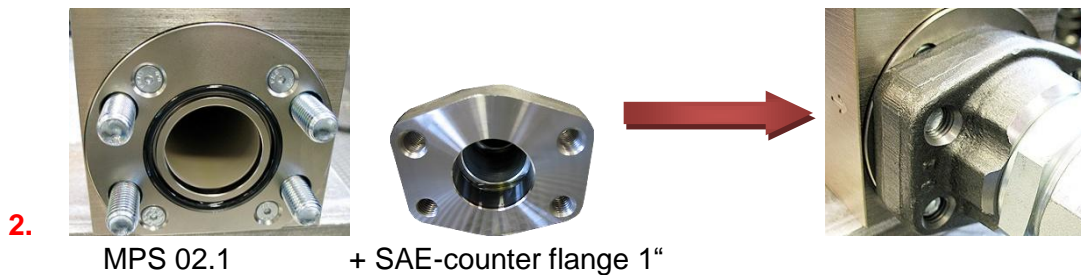
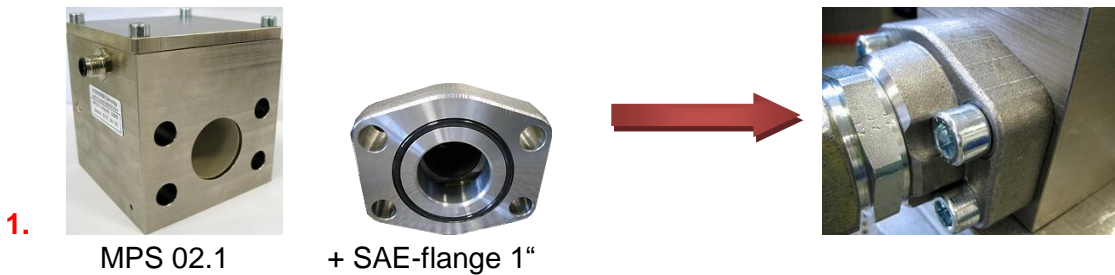

- Connect the MPS 02.1 with the included sensor cable.



2.5. Electrical connection of the MPS 02.1

- The MPS 02.1 can be coupled with nearly every PLC that is equipped with 24 V capable digital input channels.
- The MPS 02.1 is equipped with an electrical standard connection M12. With the help of this it can be connected to the MPM 01 display unit or other examination devices. (see 3.2 Pin assignment)

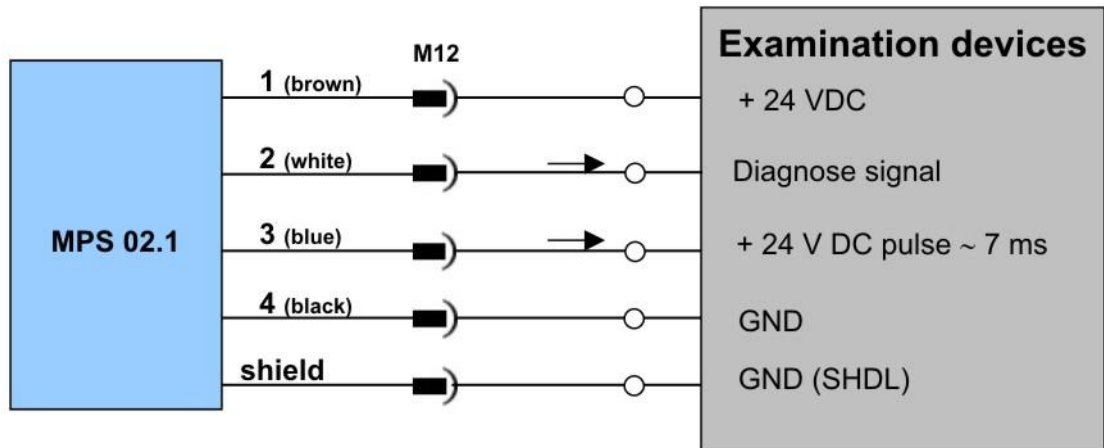

After connecting the MPS 02.1 and the power cable to your system, the sensor is ready for operation.

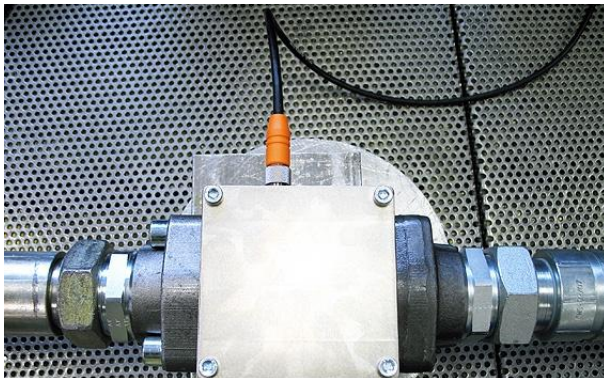

3. Appendix

3.1. Technical Data

Detection limit:	> 260 µm Fe
Limit of measurement:	max. 100 particles/ s
Operating pressure:	≤ 20 bar / ≤ 290 psi
Ambient temperature:	- 40...+ 70 °C / - 40... 158 °F
Fluid temperature range:	- 30*...+ 85 °C / - 22... 185 °F
Survival temperature range:	- 40...+ 85 °C / - 40... 185 °C
Max. volume flow:	110 l/min / 29,062 gal/ min
Min. volume flow:	30 l/min / 7,926 gal/ min
Power supply:	+ 24 V DC
Ripple:	< 300 mV _{pp}
Electrical power consumption:	max. 5 W
Analogue outputs:	1 x Signal output (24 V impulses ~ 7 ms) 1 x Diagnostic output (24 V DC, if no malfunctions)
Max. electric current on analogue outputs:	10 mA
Fluids:	Mineral oil based hydraulic- and lubricating fluids (see separate list of fluid compatibility 3.3).
Connection size:	SAE – Flansch 1”
Mass:	2 kg

* The minimum flow rate has to be ensured!

Note: The working temperature range of the MPS 02.1 depends also on the VT - behavior of the fluid. For applications with very high viscous fluids a regular operation of the sensor is only possible within a temperature range in which a sufficient oil flow (30 l/ min.) can be ensured!

3.2. Pin assignment

Pin 1	+ 24 V DC
Pin 2	Diagnostic
Pin 3	Output
Pin 4	GND
Pin 5	-----

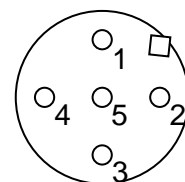
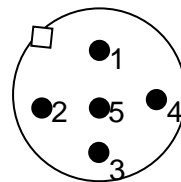

Cable colour (Connection cable):

1: brown	(+ 24 V DC)	Power supply
2: white	(+ 24 V DC, if no malfunctions)	Diagnostic output
3: blue	(+ 24 V DC impulses ~ 7 ms)	Output
4: black	GND	Ground
Shield:	GND	

3.3. Application areas - Compatibility

- Hydraulic oils H, HL, HLP, and HV
- Gear oils C, CL, CLP
- Motor oils, gas oils
- MIL-H-5606 E
- Vegetable oils (HTG, Triglyceride)
- Synthetic ester (HEES)
- Polyalphaolefin (PAO)
- Polyglycol (PG)

3.4. Trouble shooting

No settings of the MPS 02.1 are done by the operator.

In case of malfunctions, please contact Internormen Technology GmbH.

To check your warranty and to answer questions by phone we need the serial number and the date of purchase of the instrument.

3.5. Shipment/ spare parts



- (1) Sensor MPS 02.1
- (2) Sensor cable, L = 5 m
- (3) O-Ring 32,9 x 3,53, P70 (NBR)
- (4) Cylinder screw ISO 4762 – M10 x 140 (4 St.)
- (5) Instruction manual
- (6) Line filter
- (7) Earth connection cable M4

Article No.:

- 335710
- 332597
- 318850
- 310953
- 342645
- 336220
- 336218

North America — HQ

70 Wood Ave., South, 2nd Floor
Iselin, NJ 08830
Toll Free: (800) 656-3344
(North America Only)
Voice: (732) 767-4200

China

No. 3, Lane 280, Linhong Road
Changning District, 200335
Shanghai, P.R. China
Voice: +86-21-5200-0099

Singapore

4 Loyang Lane #04-01/02
Singapore 508914
Voice: +65-6825-1668

Europe/Africa/Middle East

Friedensstraße 41
D-68804 Altlussheim, Germany
Voice: +49-6205-2094-0

Auf der Heide 2
53947 Nettersheim, Germany
Voice: +49-2486-809-0

An den Nahewiesen 24
55450 Langenlonsheim, Germany
Voice: +49 6704 204-0

Brazil

Av. Julia Gaioli, 474 –
Bonsucesso
07251-500 – Guarulhos, Brazil
Voice: +55 (11) 2465-8822

For more information, please e-mail us at filtrationinfo@eaton.com

Visit us online eaton.com/filtration for a complete list of Eaton's filtration products.

©2012 Eaton Corporation. All Rights Reserved.
All trademarks and registered trademarks are the property of their respective owners. Litho USA.

All information and recommendations appearing in this brochure concerning the use of products described herein are based on tests believed to be reliable. However, it is the user's responsibility to determine the suitability for his own use of such products. Since the actual use by others is beyond our control, no guarantee, expressed or implied, is made by Eaton as to the effects of such use or the results to be obtained. Eaton assumes no liability arising out of the use by others of such products. Nor is the information herein to be construed as absolutely complete, since additional information may be necessary or desirable when particular or exceptional conditions or circumstances exist or because of applicable laws or government regulations.



Powering Business Worldwide

